



KOALA KARE PRODUCTS

Installation and Operation Instructions



KB112-01RE

Baby Changing Station

Cambiador Plegable

Table à Langer

Babywickelstation

IMPORTANT. RETAIN FOR FUTURE REFERENCE. READ CAREFULLY.

IMPORTANTE. GUÁRDELO PARA FUTURAS CONSULTAS. LEER ATENTAMENTE.

IMPORTANT. À CONSERVER POUR INFORMATION. À LIRE ATTENTIVEMENT.

WICHTIG. ZUR SPÄTEREN BEZUGNAHME AUFBEWAHREN. BITTE SORGFÄLTIG DURCHLESEN.

Your unit should be installed to meet 2010 ADA Standards for Accessible Design when and where applicable.
You are responsible for the safe operation of this unit.



KB112-01RE Operating Instructions

Please Note: To assure proper installation, it is suggested that a qualified person or carpenter install the Koala Baby Changing Station. Koala Kare Products will not be responsible if the station is not installed properly. Koala Baby Changing Stations are intended for use on an existing countertop surface that is capable of holding significant weight. Unit should be permanently mounted to the countertop surface per the installation instructions. When an infant is placed onto the changing surface, use strap and buckle to secure infant to the changing surface. Never Leave Child Unattended. You are responsible for the safe operation and use of this product. Not intended to hold more than 50 lbs.

Restraint System: To fasten the waist restraint strap, place strap around child's midsection, and push spring tabs into buckle until both spring tabs lock in place with an audible "click". Straps can be adjusted to make strap tighter or looser as required.

Inspection Criteria:

- A properly maintained baby changing station:
- Is free of any cracks or damage that can cause injury.
- Has both ends of a functioning, non-frayed strap:
buckle clicks when closed and strap is attached to unit at both ends.
- Check labels and replace as needed.

Tools Needed



gloves



drill



pencil

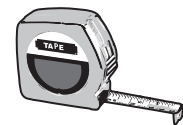

measuring
tape



1/8" (3 mm)
(regular & masonry)
drill bits



Phillips head
screwdriver

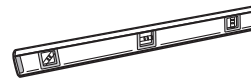

level



Sealant (Silicone)

Hardware Provided



eight 10 x 1/4" Phillips
panhead wood screws

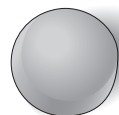

eight screw covers



eight screw
cover bases



KB112-01RE Installation Instructions

Step 1.

Remove changing station from the shipping container and check for any freight damage. Identify the best location for installing the unit.

Step 2.

Remove the rough opening template from the shipping carton. Remove paper template and lay it on the surface where the unit will be mounted. Drill hole in interior of rough opening to allow saw access. Cut out rough opening.

Step 3.

Construct under counter support as shown in the illustration. Support should be 3" below bottom of mounting surface.

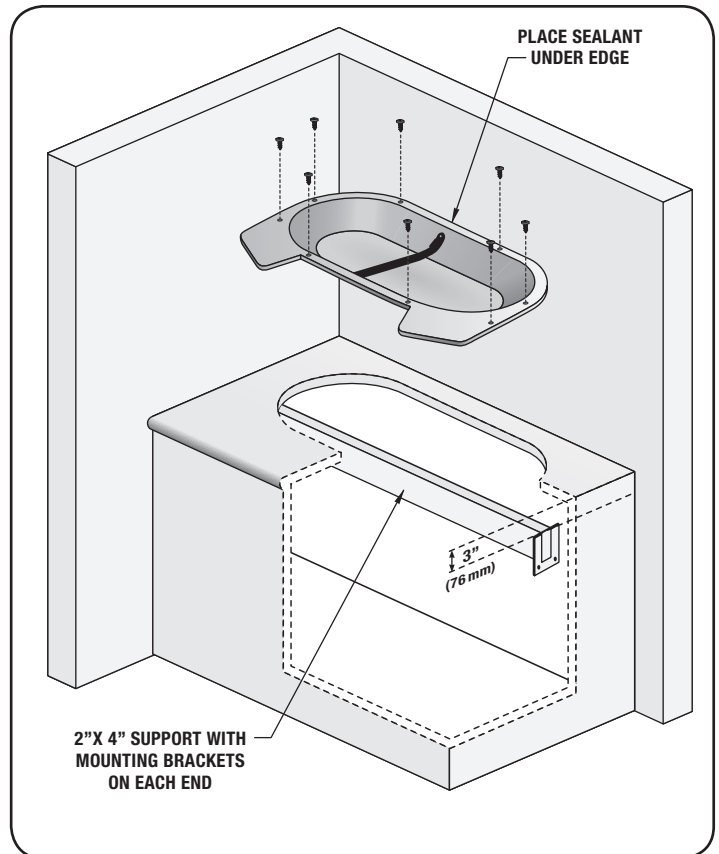

Step 4.

Place the Countertop Baby Changing Station (BCS) onto counter surface and place in desired position. Using the mounting holes as a guide, mark the screw hole locations with a pencil. Remove BCS and drill holes with a 1/8" diameter drill bit.

Step 5.

Place BCS onto counter surface using the drilled holes as a guide. Slide screw through the screw cover base. Screw fasteners through holes into countertop surface. Securely snap screw cover onto screw cover base. Apply a suitable water sealant (not provided) such as silicone around the base of the BCS.

***Note: If drilling into marble or granite, take care to not crack or chip the surface area while drilling. Larger drill bit may be necessary.**



KB112-01RE ASTM F2285-04 (2016)

ENGLISH

⚠ WARNING:
Never leave child unattended.

⚠ WARNING: Avoid serious injury from falling or sliding out. Always use restraint system.

⚠ WARNING: Designed for Infants Only. Age up to 3.5 years and weighing less than 50 lbs (22.7 kg). Keep one hand on the child at all times. Parcels or accessory items, or both, placed on the unit may cause the unit to become unstable.



FRANÇAIS

⚠ ATTENTION:
Ne laissez jamais un enfant sans surveillance.

⚠ ATTENTION: Évitez les blessures occasionnées par une chute ou une glissade. Utilisez toujours le système de retenue.

⚠ ATTENTION: Conçue uniquement pour les jeunes enfants. Jusqu'à 3 ans et demi et moins de 50 lb (22.7 kg). Conservez une main sur l'enfant à tout moment. Tout paquet ou accessoire placé sur la table peut créer un déséquilibre.



ESPAÑOL

⚠ ADVERTENCIA:
No deje nunca al niño desatendido.

⚠ ADVERTENCIA: Evite que el niño se lesione por caerse o resbalarse del cambiador. Use siempre el sistema de sujeción.

⚠ ADVERTENCIA: Diseñado exclusivamente para bebés. Hasta 3 años y medio de edad y con un peso inferior a 50 libras (22,7 kg aproximadamente). Mantenga siempre al niño sujeto con una mano.

Colocar paquetes o accesorios, o ambas cosas, encima del cambiador puede provocar que se desestabilice.

DEUTSCH

⚠ WARNUNG:
Das Kind niemals unbeaufsichtigt lassen.

⚠ WARNUNG: Ernsthaftige Verletzungen durch Herausfallen oder Herausrutschen verhindern. Immer das Rückhaltesystem verwenden.

⚠ WARNUNG: Dieses Produkt ist nur für Kleinkinder bis zu 3 1/2 Jahren und einem Gewicht von höchstens 50 lbs. (22.7 kg) vorgesehen. Das Kind immer mit einer Hand festhalten.

Durch Ablegen von Päckchen und Zubehör auf der Wickelstation kann diese instabil werden.